

Senza *Designs*

- SINGLE STOREY -



SENZA - ONE OF YOUR FAVOURITES

SENZA-tional range of designs popular with modern families.

Our Senza design range has drawn its inspiration from the successful string of designs from the Sebring and Carlisle ranges, but with its own individual style, making it stand apart from the rest.

With generous-sized bedrooms and large open-plan living spaces, the Senza range gives modern families a variety of living / entertaining zones that can sometimes be an afterthought when deciding on the right design for your family home.

The Senza range is gaining momentum in popularity, and we now have this design on display at various locations. We have two homes on display at HomeWorld Leppington and HomeWorld Box Hill, at which both designs fit best on 12.5m blocks. Perfect for those wanting to maximise their living space even on a narrower block.

The designs on display at HomeWorld Warnervale, HomeWorld Thornton, HomeWorld Marsden Park and Housing World Wongawilli showcase fantastic features like four bedrooms, a large media room, an alfresco area with great sized family room and a functional kitchen, so it's no wonder that this design is rising in popularity.

Our Aspire options are growing in popularity and have been created with you in mind, so you can build your home your way to suit your lifestyle.

In choosing an Allworth Home, you will benefit from 40 years of master-built experience. We have mastered the planning and building process, honed to a point, being recognised by families in NSW to be one of the most efficient builders in New South Wales.

Take a look through our new look brochure and talk to one of our friendly New Home Consultants.

WHERE TO VIEW THE SENZA ON DISPLAY OPEN 7 DAYS FROM 10AM TO 5PM

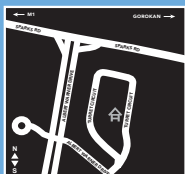

HOMEWORLD WARNERVALE
29 Turret Circuit,
Warnervale NSW 2259
P. 4394 0821

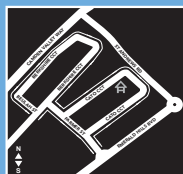

HOMEWORLD LEPPINGTON
33 Cato Circuit,
Leppington NSW 2179
P. 9043 5766

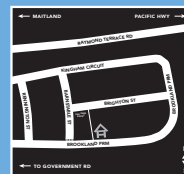

HOMEWORLD THORNTON
17 Brookland Promenade,
Thornton NSW 22322
P. 4934 7467

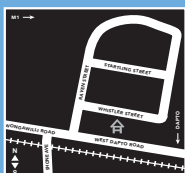

HOUSING WORLD WONGAWILLI
8 Whistler Street,
Wongawilli NSW 2530
P. 4261 5359

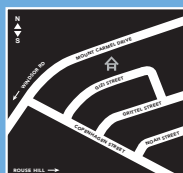

HOMEWORLD BOX HILL
20 Gizi Street,
Box Hill NSW 2765
P. 9627 2600

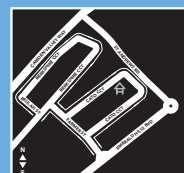

HOMEWORLD MARSDEN PARK
9 Ellison Street,
Marsden Park NSW 2765
P. 9838 1763



SENZA - DISPLAYS

Senza 12.5 Four 22 on display at HomeWorld Leppington



SENZA FOUR 25

4 BEDROOM / MEDIA / ALFRESCO

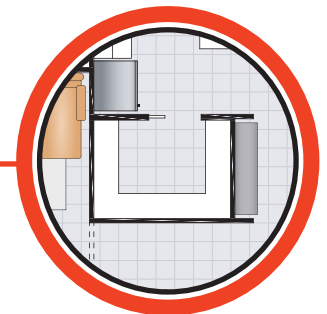
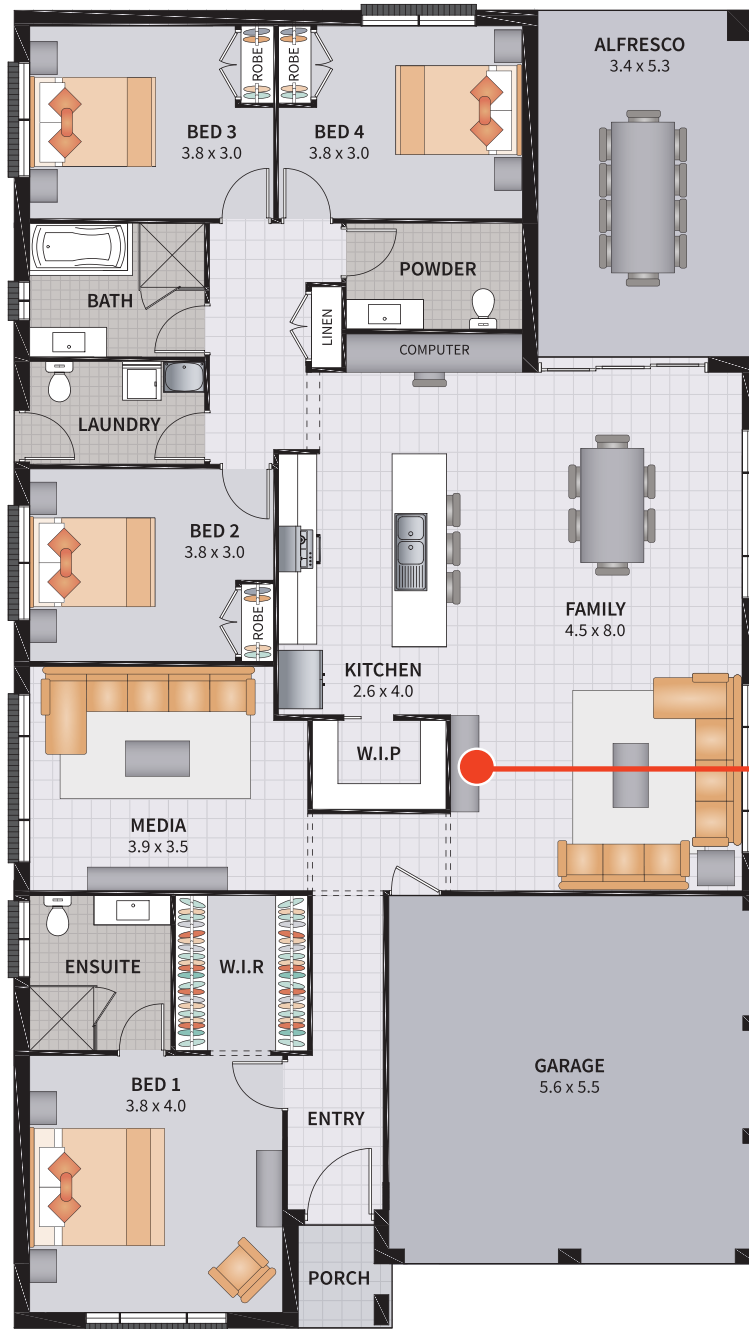

your choice

**ALTERNATE
NIB WALLS HERE**

SUITS 13.5m x 28m REGULAR LOTS

Width: 11.57m	Depth: 20.50m
Size: 24.92 sq.	Area: 231.50m ²

SENZA FOUR 25 CONVERSE

4 BEDROOM / CONVERSE / MEDIA / ALFRESCO

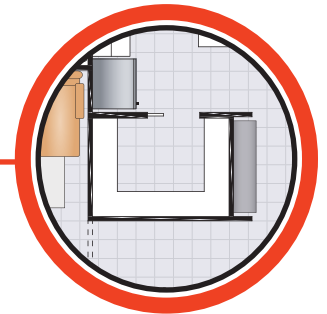
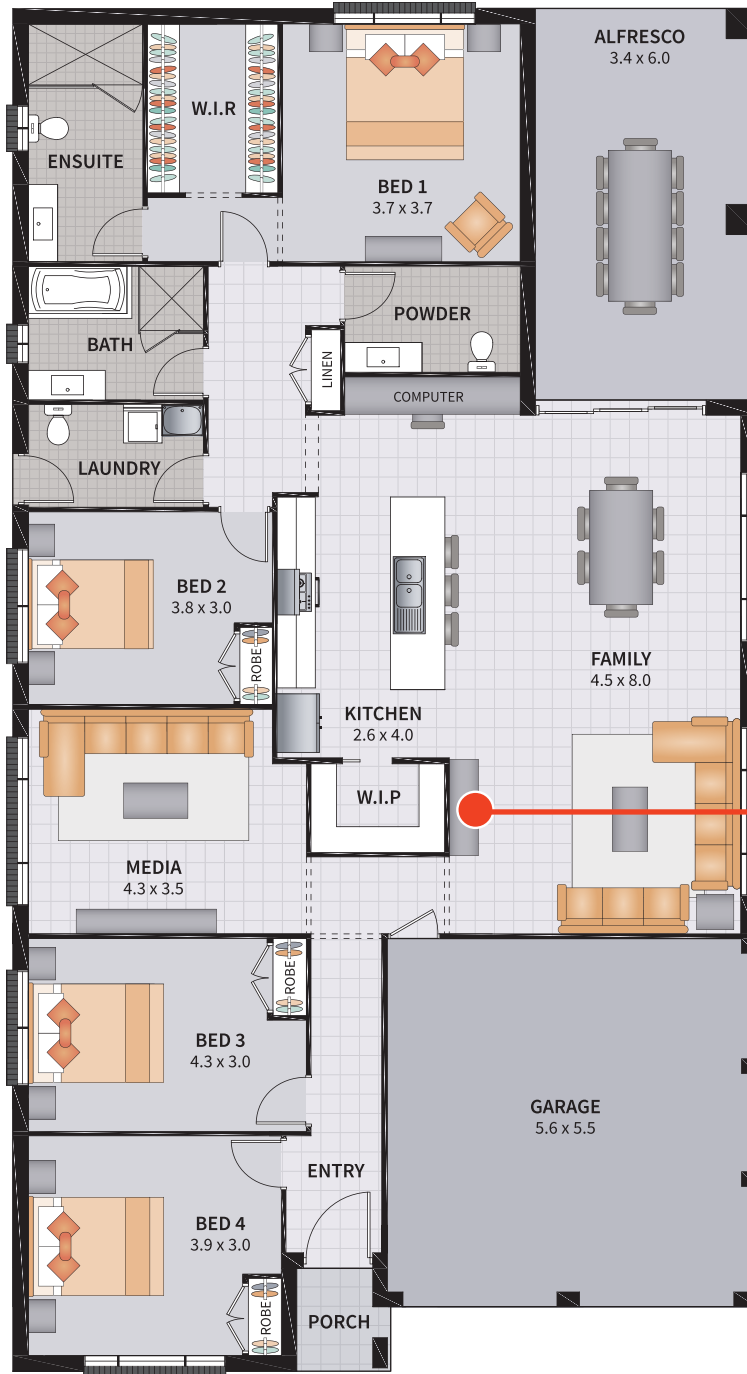

your choice

**ALTERNATE
NIB WALLS HERE**

 **SUITS 13.5m x 30m REGULAR LOTS**

Width: 11.57m	Depth: 21.20m
Size: 25.79 sq.	Area: 239.60m ²

SENZA FOUR 25.1

4 BEDROOM / MEDIA / STUDY / ALFRESCO

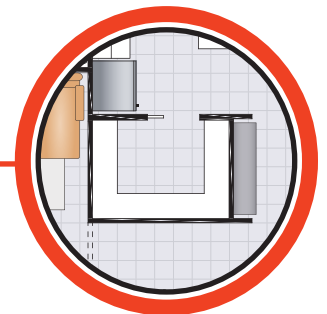
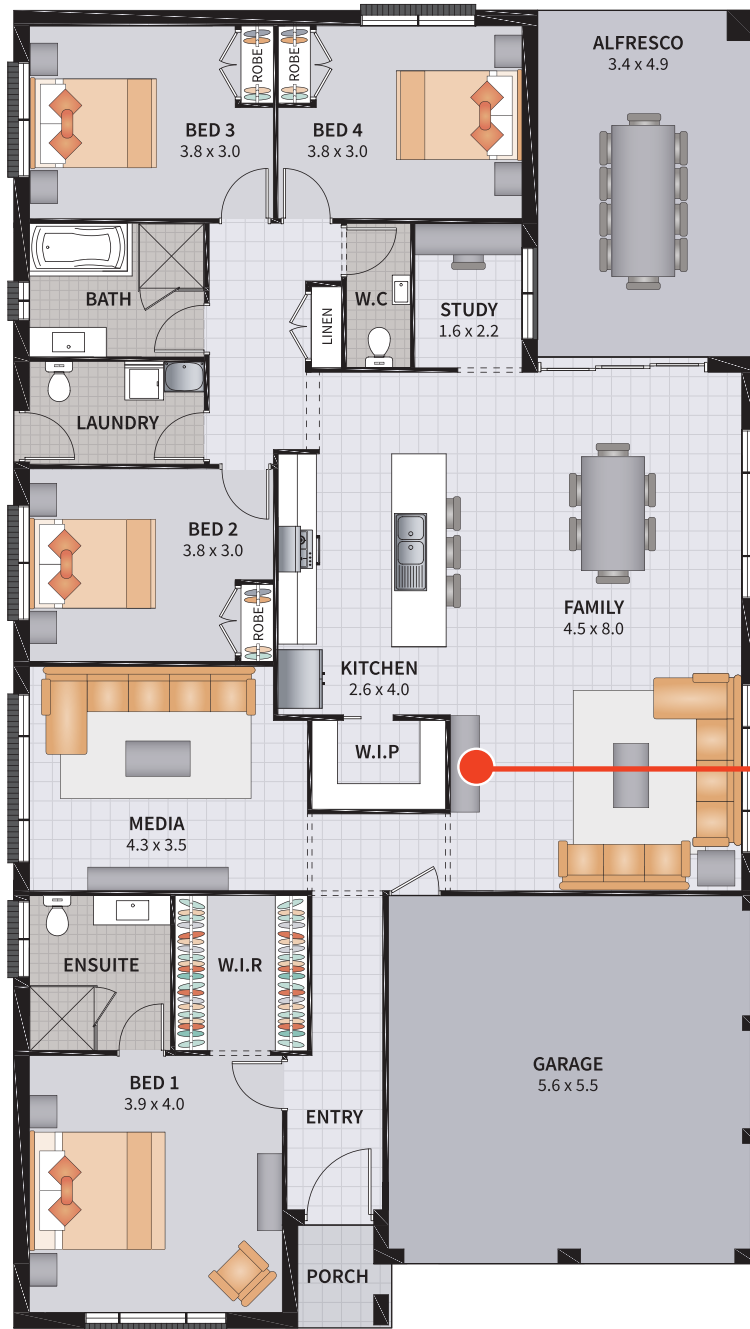

your choice

**ALTERNATE
NIB WALLS HERE**

SUITS 13.5m x 28m REGULAR LOTS

Width: 11.57m	Depth: 20.50m
Size: 24.92 sq.	Area: 231.50m ²

SENZA FIVE 25
5 BEDROOM / ALFRESCO

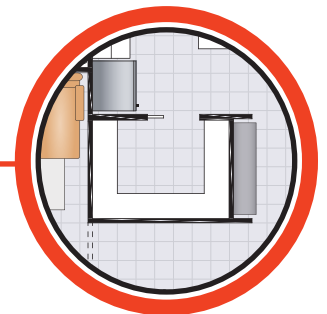
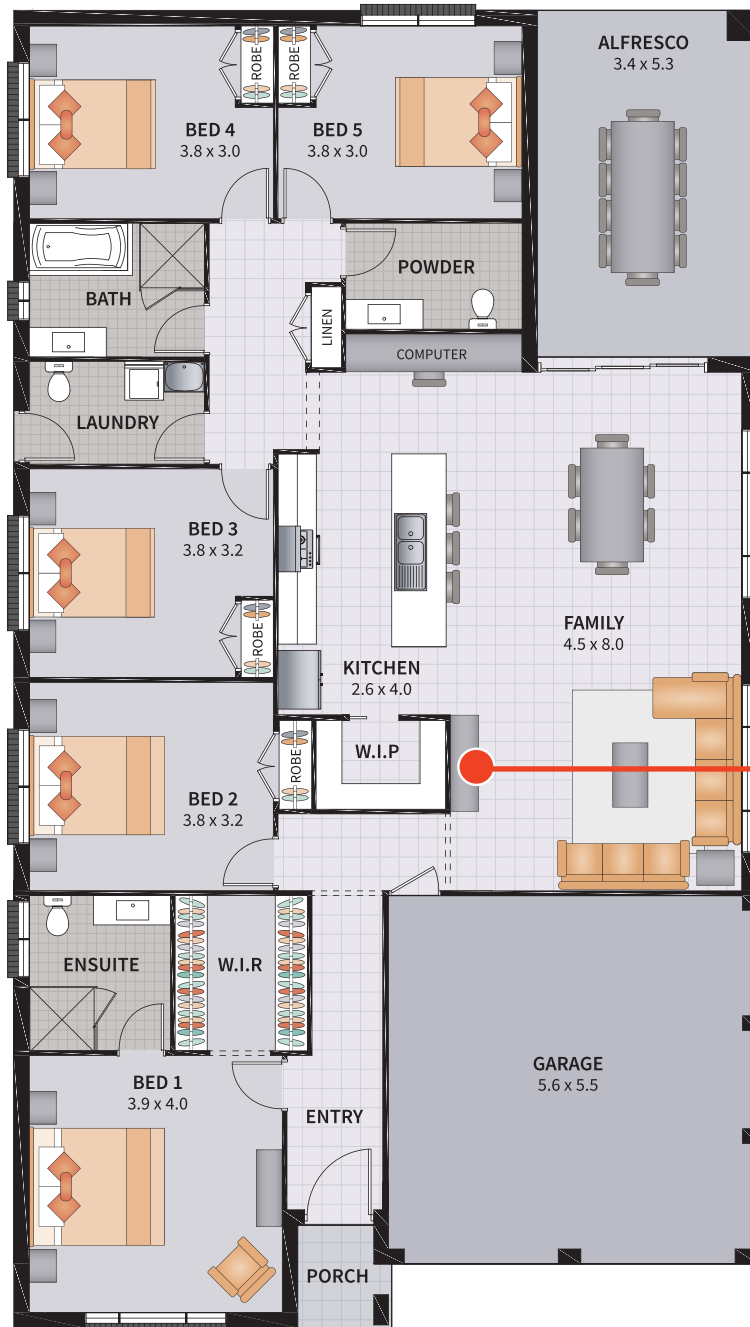

your choice

**ALTERNATE
NIB WALLS HERE**

 **SUITS 13.5m x 28m REGULAR LOTS**

Width: 11.57m	Depth: 20.50m
Size: 24.92 sq.	Area: 231.50m ²

SENZA FOUR 27

4 BEDROOM / MEDIA / ACTIVITIES / ALFRESCO

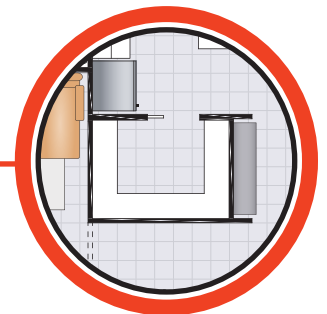

your choice

**ALTERNATE
NIB WALLS HERE**

SUITS 13.5m x OVER 30m REGULAR LOTS

Width: 11.57m	Depth: 23.57m
Size: 27.12 sq.	Area: 251.92m ²



ASPIRE *options*

Get the options
you want at
the budget that
suits you.



Visit allworthhomes.com.au/aspire-package
to find out more about these options

SENZA FOUR 27.1

4 BEDROOM / ACTIVITIES / ALFRESCO / MIRRORED REAR

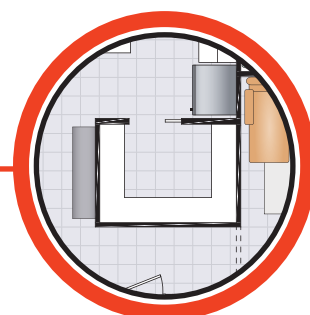
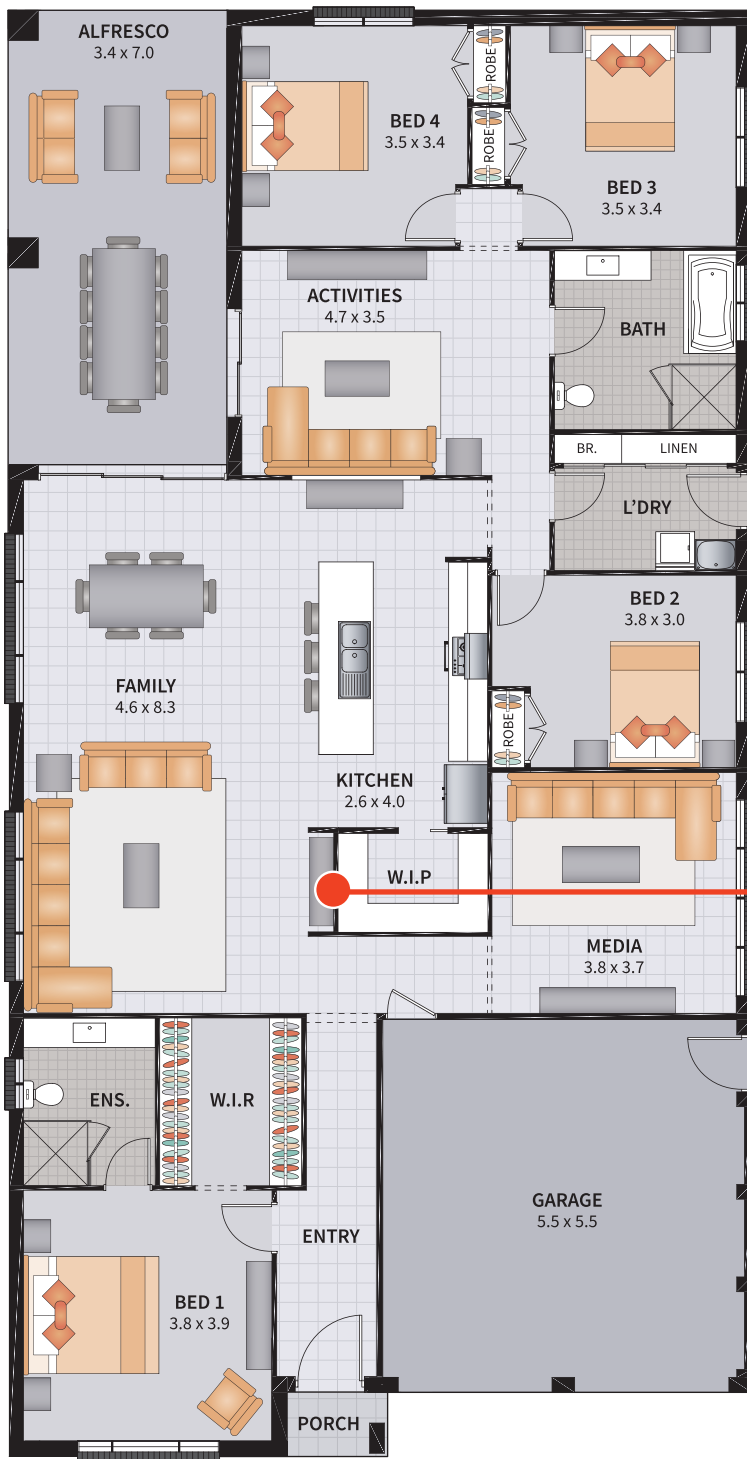

your choice

ALTERNATE NIB
WALLS REMOVED



SUITS 13.5m x 30m REGULAR LOTS

Width: 11.57m

Depth: 22.50m

Size: 27.41 sq.

Area: 254.68m²



AVAILABLE TO MOST SENZA DESIGNS

SENZA FOUR 27.2

4 BEDROOM / MEDIA / GRAND ALFRESCO

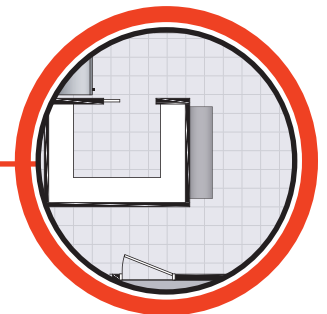

your choice

**ALTERNATE NIB
WALLS REMOVED**

SUITS 13.5m x 30m REGULAR LOTS

Width: 11.57m	Depth: 22.50m
Size: 27.41 sq.	Area: 254.68m ²

SENZA FOUR 27.3

4 BEDROOM / MEDIA / ACTIVITIES / WORKSHOP

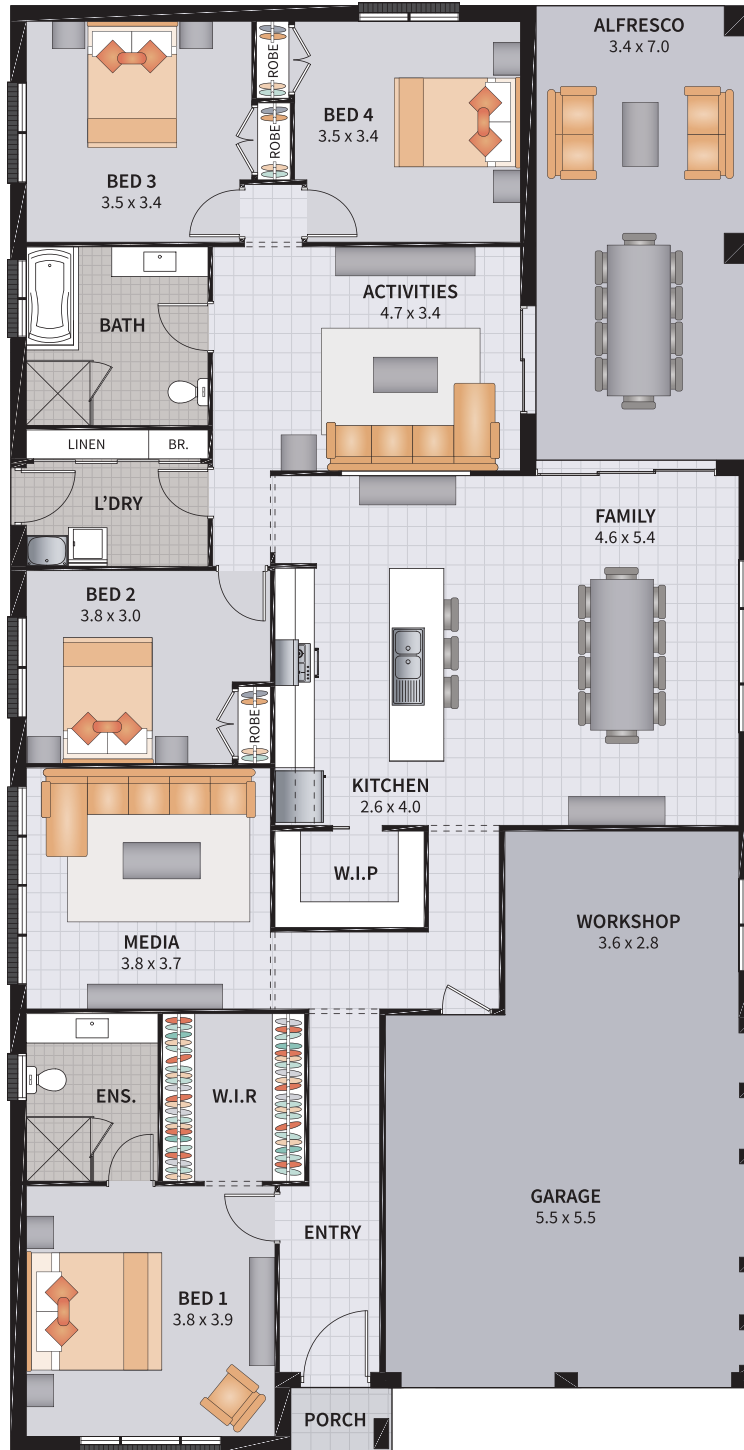

SUITS 13.5m x 30m REGULAR LOTS

Width: 11.57m	Depth: 22.50m
Size: 27.41 sq.	Area: 254.68m ²

SENZA FOUR GUEST 27

4 BEDROOM GUEST / MEDIA / ALFRESCO

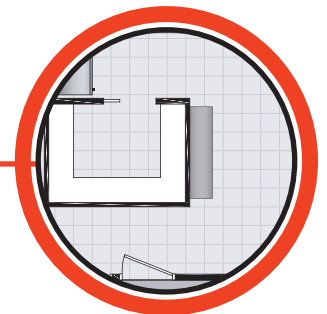
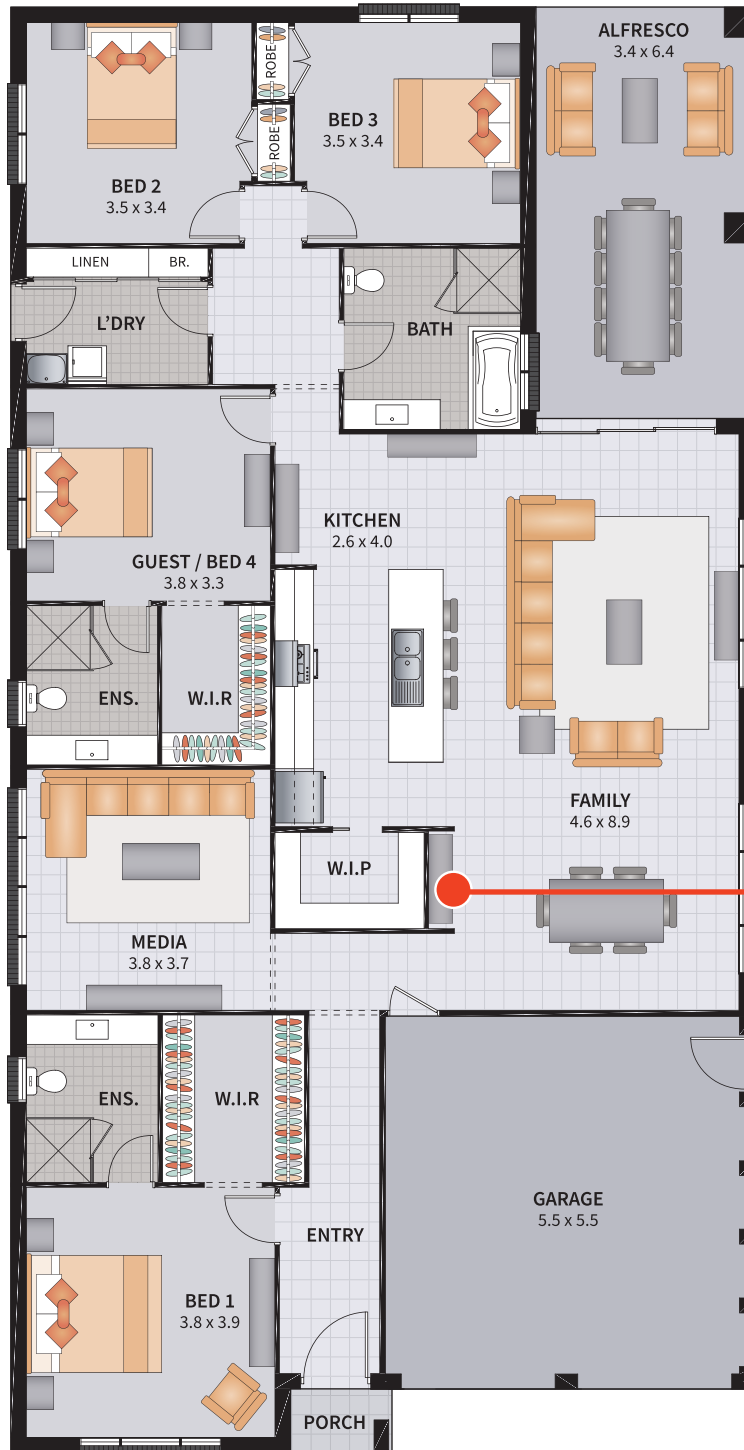

your choice

**ALTERNATE NIB
WALLS REMOVED**

SUITS 13.5m x 30m REGULAR LOTS

Width: 11.57m	Depth: 22.50m
Size: 27.41 sq.	Area: 254.68m ²

SENZA FIVE 27 CONVERSE

5 BEDROOM / CONVERSE / MEDIA / ALFRESCO

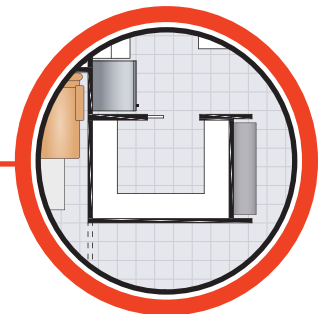

your choice

**ALTERNATE
NIB WALLS HERE**

 **SUITS 13.5m x OVER 30m REGULAR LOTS**

Width: 11.57m	Depth: 23.34m
Size: 27.28 sq.	Area: 253.46m ²

SENZA FIVE 28

5 BEDROOM / MEDIA / ACTIVITIES / ALFRESCO

 5
  2.5
  2
  1

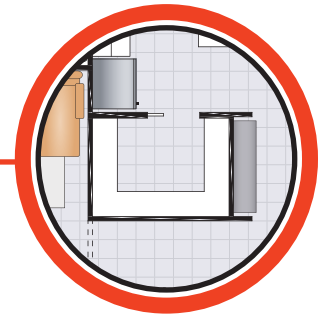

your choice

**ALTERNATE
NIB WALLS HERE**

SUITS 13.5m x OVER 30m REGULAR LOTS

Width: 11.57m	Depth: 23.67m
Size: 28.87 sq.	Area: 268.18m ²

SENZA 12.5 FOUR 25

4 BEDROOM / 12.5m / MEDIA / ACTIVITIES / ALFRESCO

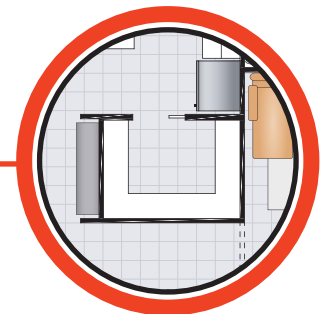

your choice

ALTERNATE
NIB WALLS HERE

SUITS 12.5m x 30m REGULAR LOTS

Width: 10.66m	Depth: 22.50m
Size: 25.22 sq.	Area: 234.34m ²

SENZA 12.5 FOUR 22

4 BEDROOM / 12.5m / MEDIA / ALFRESCO





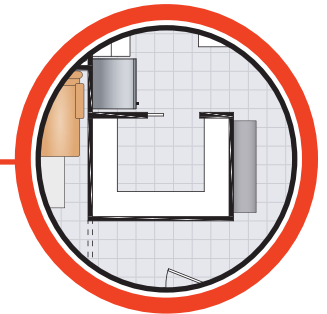

4 2.5 2 1



your choice

ALTERNATE NIB
WALLS REMOVED

SUITS 12.5m x 28m REGULAR LOTS

Width: 10.66m	Depth: 20.50m
Size: 22.93 sq.	Area: 213.02m ²

SENZA 12.5 FOUR 22.1

4 BEDROOM / 12.5m / MIRRORED REAR / ALFRESCO





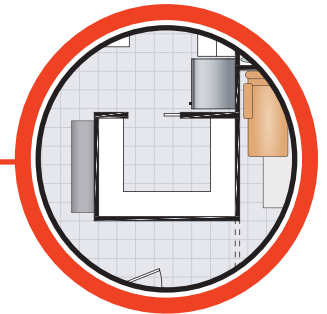
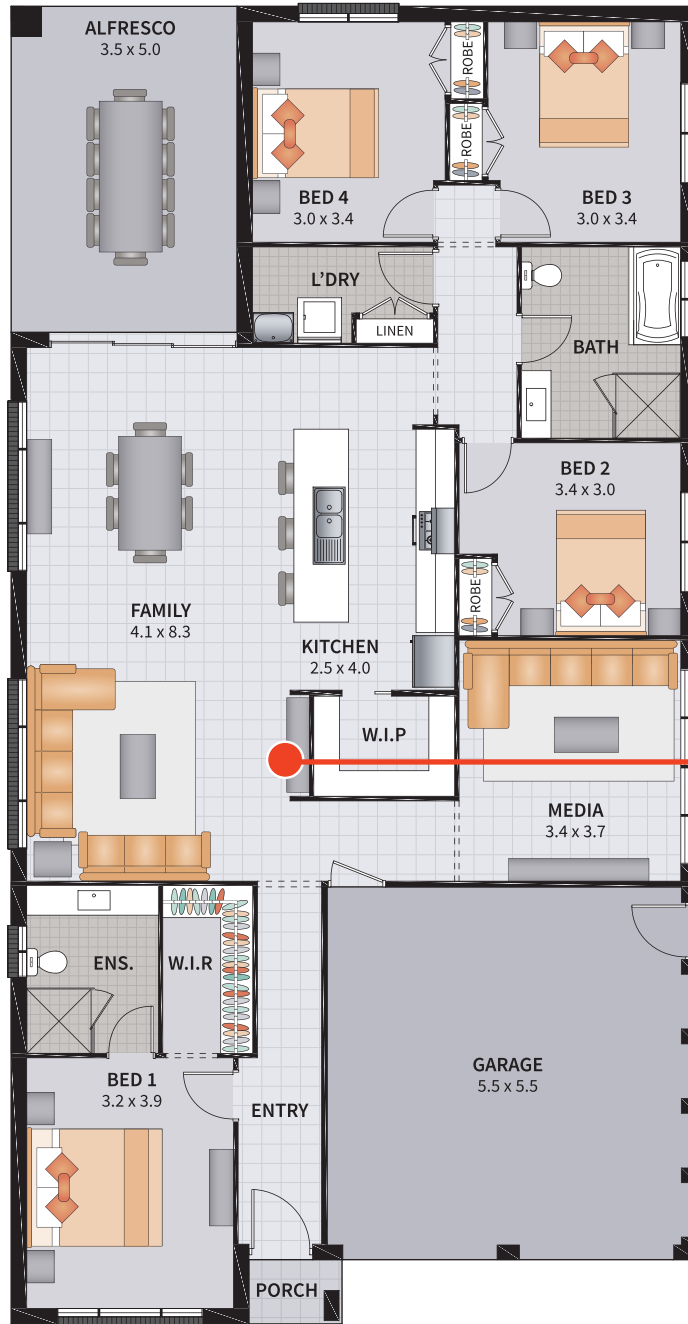

4
2.5
2
1



your choice

**ALTERNATE NIB
WALLS REMOVED**

SUITS 12.5m x 28m REGULAR LOTS

Width: 10.66m	Depth: 20.50m
Size: 22.93 sq.	Area: 213.02m ²

SENZA - FAÇADES

FAÇADE DISPLAYED AT HOMEWORLD WARNERVALE



NEW HAMPTONS 24°



ALTO 24°



BIZANTE 24°

DISPLAYED AT HOUSING WORLD WONGAWILLI



CAPE 24°



CLASSIC 24°

DESIGN AND FAÇADE ON DISPLAY AT THAT LOCATION

FAÇADE ONLY ON DISPLAY AT THAT LOCATION

FAÇADE DISPLAYED AT HOMEWORLD THORNTON



MODERNIST 24°



COASTAL 24°

FAÇADE DISPLAYED AT HOMEWORLD BOX HILL



COTTAGE 24°

FAÇADE DISPLAYED AT HOUSING WORLD WONGAWILLI



FLAIR 24°



HAMPSHIRE 24°

DESIGN AND FAÇADE ON DISPLAY AT THAT LOCATION

FAÇADE ONLY ON DISPLAY AT THAT LOCATION

SENZA - FAÇADES

FAÇADE DISPLAYED AT HOMEWORLD THORNTON



WEST HAMPTONS 24°

FAÇADE DISPLAYED AT HOMEWORLD MARSDEN PARK & HOUSING WORLD NOWRA



HAMPTONS 24°



LARGO 24°

DISPLAYED AT HOMEWORLD WARNERVALE



METRO 24°

FAÇADE DISPLAYED AT HOMEWORLD WARNERVALE



PAVILLION 24°

DESIGN AND FAÇADE ON DISPLAY AT THAT LOCATION

FAÇADE ONLY ON DISPLAY AT THAT LOCATION



PORTICO 24°



RAZA 24°

DISPLAYED AT HOMEWORLD MARSDEN PARK



RESORT 24°

FAÇADE DISPLAYED AT HOMEWORLD WARNERVALE



TERRACE 24°

FAÇADE DISPLAYED AT HOMEWORLD THORNTON



URBAN 24°

DISPLAYED AT HOMEWORLD THORNTON & HOMEWORLD LEPPINGTON



VERVE 24°

FAÇADE DISPLAYED AT HOUSING WORLD WONGAWILLI & HOMEWORLD BOX HILL



VISTA 24°



VISTA LARGO 24°

DESIGN AND FAÇADE ON DISPLAY AT THAT LOCATION

FAÇADE ONLY ON DISPLAY AT THAT LOCATION



Because you're worth it!

allworthhomes.com.au

1300 769 988

The content shown is the property of Allworth Constructions and may not be copied in whole or part without the express written permission of the company. Lot width and Lot depth sizes are to be used a guide only and is subject to Authority requirements, Developer guidelines and site conditions. Façades shown are for illustration purposes only and may alter structure and dimensions slightly depending on design. For more information contact your Allworth New Home Consultant. The content is correct at time of publishing (12.8.24) and supersedes any previous version published. AWH-SS-Brochure-Senza-12.8.24

Allworth Constructions Pty Limited. ABN 78 002 565 353. BL34459.